

Name: _____

Science 9: Series, Parallel, Power, and Efficiency Assignment

Series Circuits:

#1) True or False (5pts):

- a) A series circuit has different branches with resistors _____
- b) Current is constant throughout a series circuit _____
- c) The total current in the circuit is equal to the current through only 1 resistor _____
- d) Voltage is constant throughout a series circuit _____
- e) The total voltage of a parallel circuit is equal to the voltage across only 1 resistor _____

Calculations:

#2)

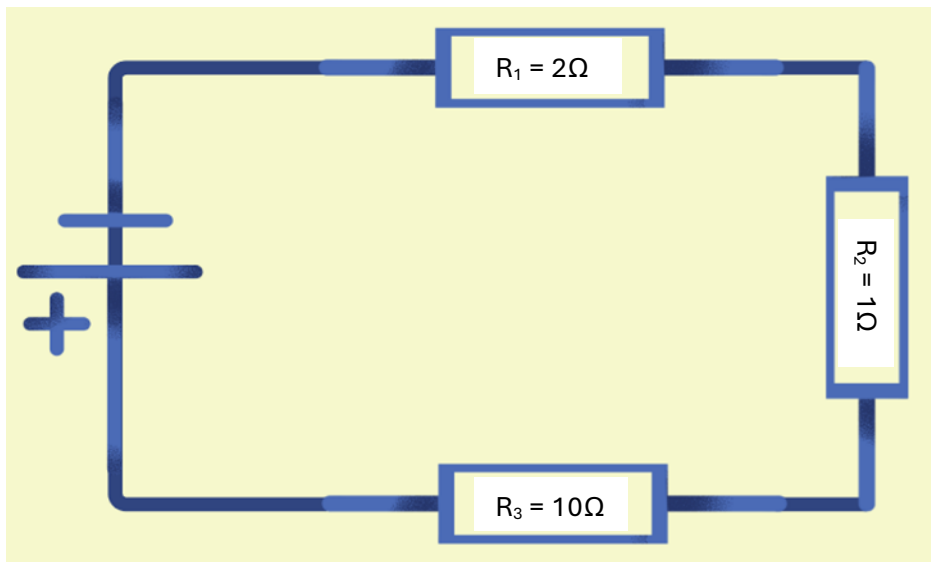

If R_3 gets 5V of electricity what is the current through the circuit? (3pts)

What is the equivalent resistance? (3pts)

#3)

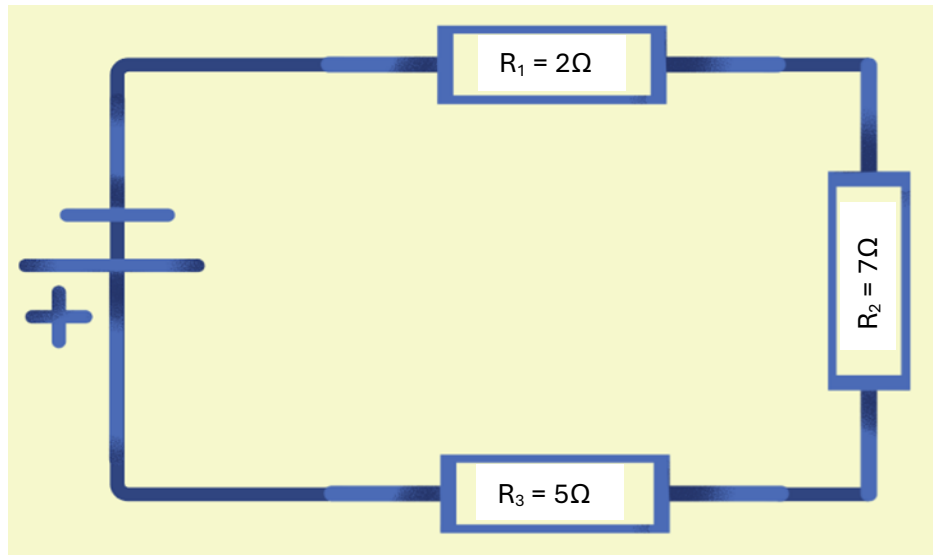

What is the equivalent resistance? (3pts)

The current through the circuit is 1.5A. What is the voltage of the battery? (3pts)

Parallel Circuits:

#4) True or False (5pts):

- a) A parallel circuit has all resistors in one singular loop _____
- b) Each branch of a parallel circuit has its own current _____
- c) The total current of the circuit is equal to the current through one branch of the circuit _____
- d) Voltage is constant throughout a parallel circuit _____
- e) Each branch has a different voltage in a parallel circuit when they have different resistors _____

Calculations:

#5)

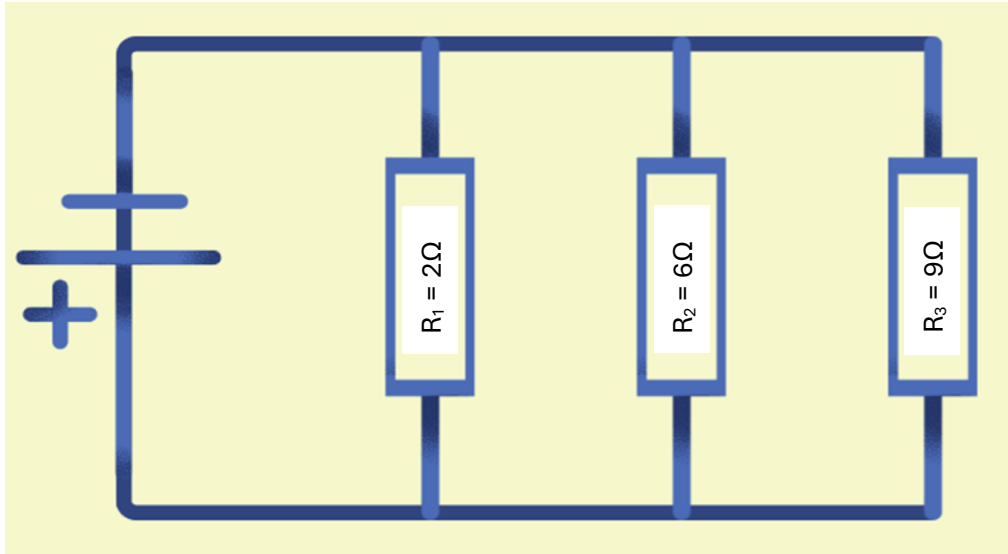

What is the equivalent resistance? (3pts)

If the circuit uses a 12V battery, what is the total current across the circuit? (3pts)

#6)

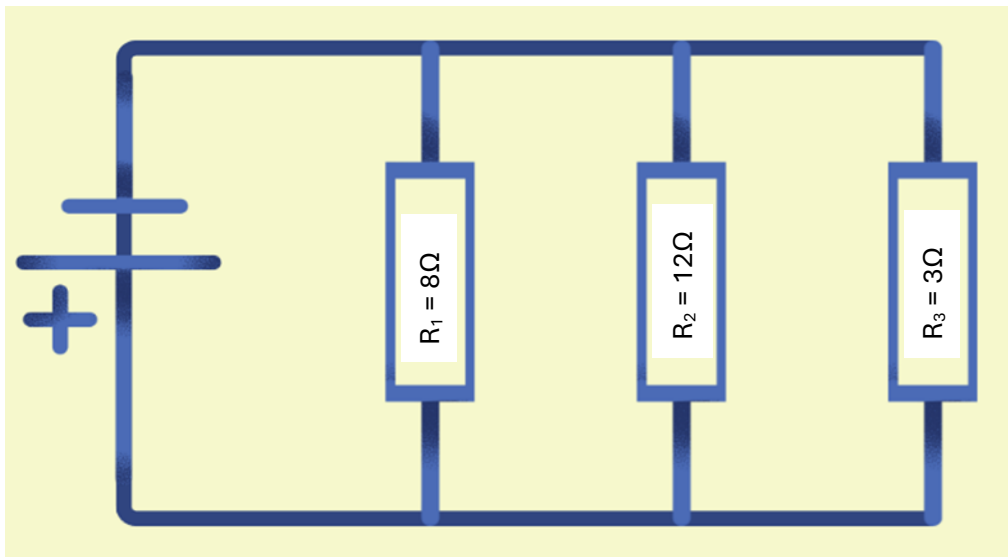

The current through R_1 is 0.5A. What is the voltage of the battery? (3pts)

What is the equivalent resistance? (3pts)

#7) Resistors (10pts)

- a) A resistor of 3Ω has a length of 10 cm. It is then stretched to a length of 30cm. What is its new resistance? (2pts)
- b) A resistor with diameter of 7mm has a resistance of 18Ω . It is then stretched so the diameter is 21mm. What is its new resistance? (3pts)
- c) A resistor of 12Ω has a length of 8cm. It is then cut in half, so each piece has a length of 4cm. What is the resistance of each piece? (2pts)
- d) A resistor with a radius of 16mm has a resistance of 5Ω . It is then shaved down so its radius is 8mm. What is its new resistance? (3pts)

Power & % Efficiency:

#8) My CD player has a power rating of 30W. I want to listen to Enchanted and Dear John by Taylor Swift (Enchanted is roughly 6 minutes and Dear John is roughly 7 minutes). How much energy does my CD player need? (3pts)

#9) I turn on my TV to play Mariokart with my brother. My TV has a power rating of 50W. If my TV needed 180,000J (180kJ) of energy, how long did my brother and I play Mariokart. (3pts)

#10) At the talent show, Clea and Mae decided to have a rap battle with Myles and Sollie. It takes 90,000J (80kJ) of energy to get the speakers to work. The speakers use 60,000J (60kJ) to make sound. What is the percent efficiency of the speakers (and who do you think won the rap battle?) (3pts)

#11) At her basketball tournament Kate finds out that the percent efficiency of the score clock is only 25%. She also finds out that it needs 123,456J (123.456kJ) of energy to work. Kate tells this to her good friend Alena and since they both love the electricity unit so much, they want to know how much energy is used to make light on the scoreboard. How much energy does it use? (3pts)

#12) I turn on my TV and see I'm only 3 episodes away from finishing Heartstopper. Each episode is roughly 30 minutes and my TV has a power rating of 50W. My TV uses 150,000J (150kJ) of energy to make the light on the screen. What is the percent efficiency of my TV? (6pts)