

Series example: For answers see series and parallel powerpoint

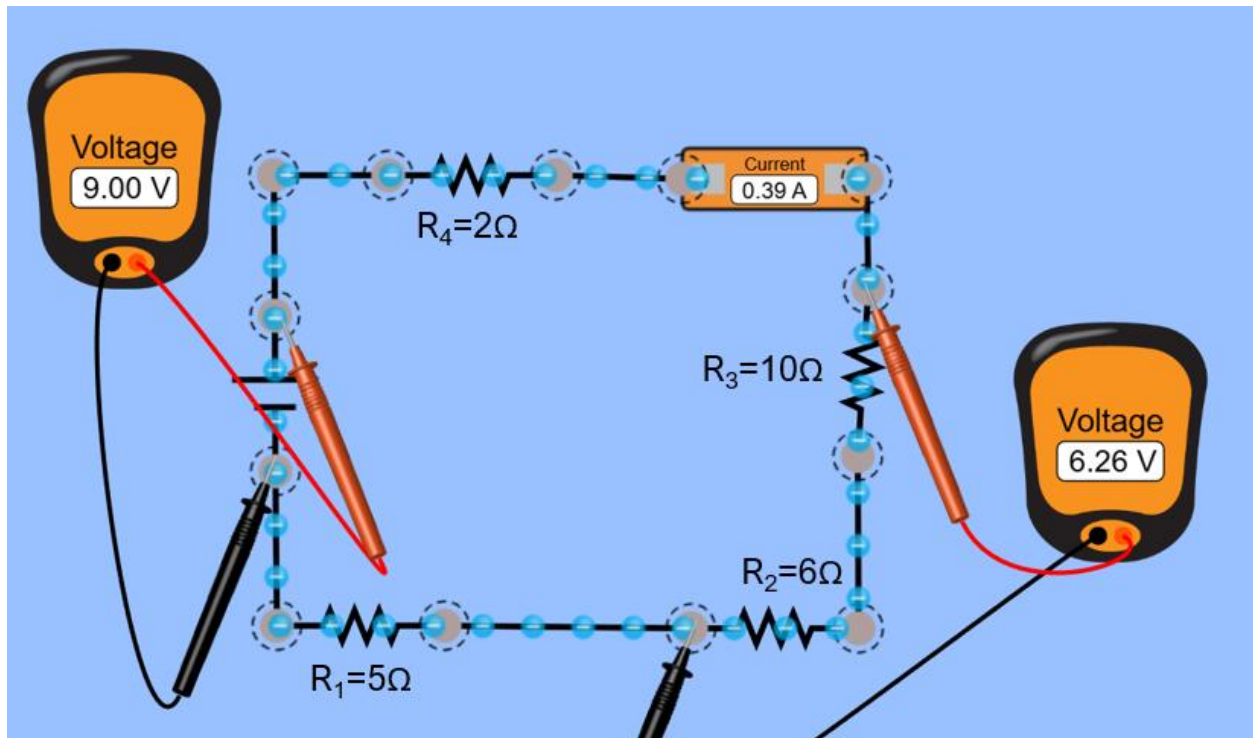

What is R_{eq} ?

What is the Voltage through R_1 ?

What is the voltage through R_4 ?

What current flows through each resistor?

Parallel example: For answers see series and parallel powerpoint

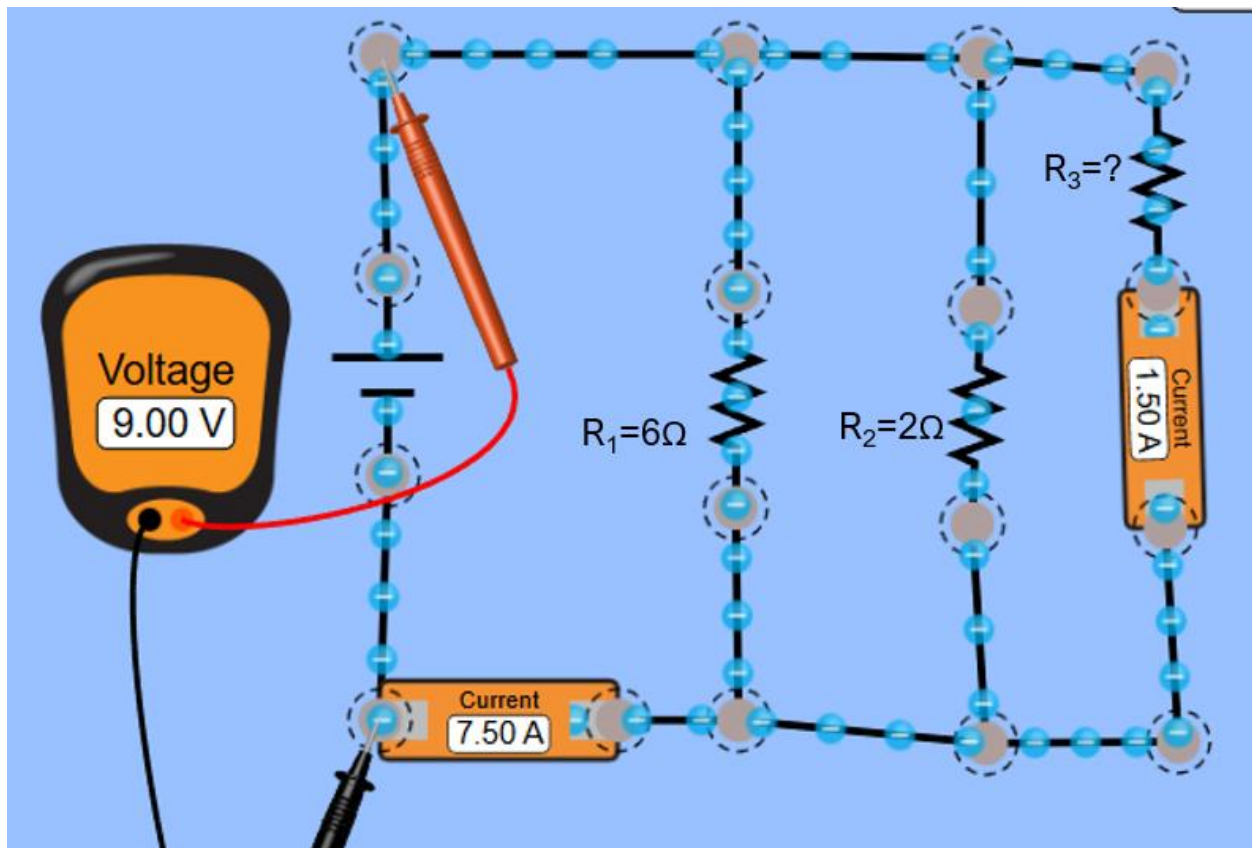

What is R_3 ?

What is The current through R_1 ?

What is the voltage through each branch?

What is R_{eq} ?

Circle the correct word

Resistors **are**/aren't conductors.

- Some conduct electricity better than others (some are more resistant than others)

Wires **do**/don't have resistance

- They do, but their resistance is so small we usually just ignore it

More on resistance:

What 4 things affect the resistance in a conductor?

- Material of the conductor
- Temperature
- Length of the conductor
- Cross-sectional area of the conductor (affected by diameter/radius)

If a $10\ \Omega$ resistor is stretched to be 5 times longer, **what is its new resistance?**

- Whatever you do to the length, you do the same to the resistance
- So if the length gets doubled, then the resistance gets doubled.
- **If a resistor is stretched so its 5 times longer, then its resistance is multiplied by 5 ($10\ \Omega \times 5 = 50\ \Omega$)**

If a 20 Ω resistor's diameter is doubled, what is its new resistance?

- Whatever you do to the diameter (or radius), you do the opposite squared to the resistance.
- If you multiply the diameter by 2, then you divide the resistance by 2²
($20\Omega/2^2 = 20\Omega/4 = 5\Omega$)

Power:

Power is defined as the amount of ENERGY used over a period of time.

Formula – Power = Energy/Time ~ $P=E/t$

Unit – Power is measured in Watts (W)

A device's or resistor's POWER_RATING is how much power it needs to work.

Percent efficiency:

The percentage of ENERGY being supplied that is actually being used for the intended purpose.

The extra energy is lost to other things, such as HEAT.

- Sorta like how lightbulbs get hot, only some of the energy makes light, the rest is lost to heat

Using power rating, we can find the ENERGY_INPUT, then if we divide the ENERGY_USED by this, and multiply it by 100, we get the PERCENT EFFICIENCY.

Formula – %Efficiency = Energy Used/Energy Input x 100%

Examples:

A stereo has a given power rating of 15W, and it is used to play August by Taylor Swift (a song that's roughly 5 minutes long). 3000J are used to make sound. What is the percent efficiency?

$$P = 15W \quad t = 5\text{minutes} = 300\text{seconds} \quad E_{\text{used}} = 3000J$$

$$P = E_{\text{input}}/t$$

$$E_{\text{input}} = P \times t = 15W \times 300\text{sec} = 4500J$$

$$\% \text{Eff} = E_{\text{used}}/E_{\text{input}} \times 100\%$$

$$\% \text{Eff} = 3000J/4500J \times 100\%$$

$$\% \text{Eff} = 67\%$$

I turn on my TV to watch an episode of Heartstopper. Each episode is roughly 30 minutes long, and my TV has a power rating of 50W. The TV produces 60000J (60kJ) of light energy. What is the percent efficiency of my TV?

$$P = 50W \quad t = 30\text{minutes} = 1800\text{seconds} \quad E_{\text{used}} = 60000J \text{ (or 60kJ)}$$

$$P = E_{\text{input}}/t$$

$$E_{\text{input}} = P \times t = 50W \times 1800\text{sec} = 90000J$$

$$\% \text{Eff} = E_{\text{used}}/E_{\text{input}} \times 100\%$$

$$\% \text{Eff} = 60\text{kJ}/90\text{kJ} \times 100\%$$

$$\% \text{Eff} = 67\%$$