



# ELECTRICITY LESSON 3 & 4: CURRENT, VOLTAGE, AND RESISTANCE

BY MR. K

## RETRIEVAL QUESTIONS:

- How does something become negatively charged?
- How does something become positively charged?
- Can protons (positive charges) move? What about neutrons?
- How do sparks form?
- What is an object that charge can move freely within?
- What is an object that charge can't move freely within?

# REVISITING THE LAB

- WHAT SHOULD HAVE HAPPENED AT EACH STATION?

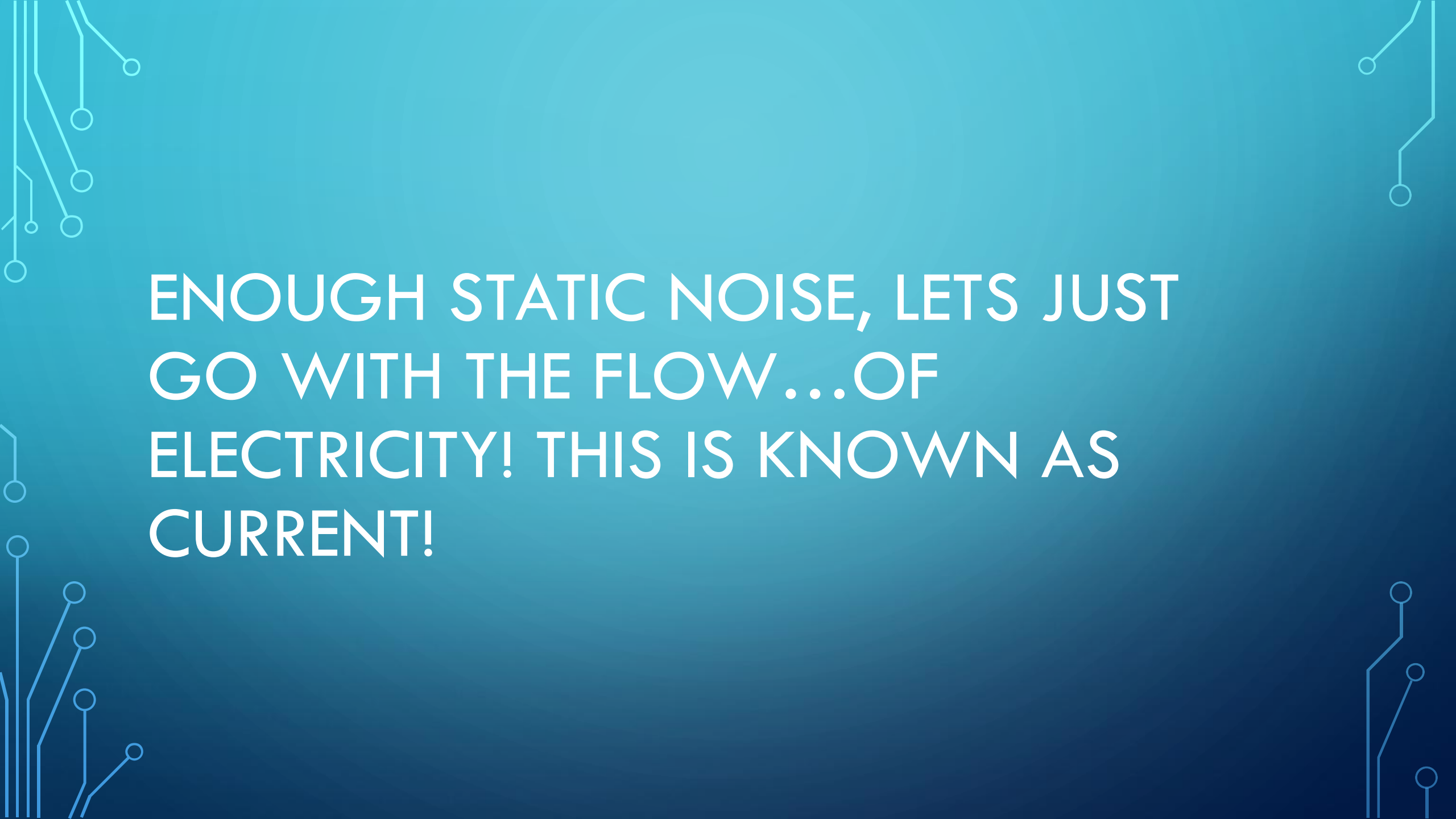
The background is a dark teal gradient. In the corners, there are decorative white line-art patterns resembling circuit board traces and nodes. The text is centered in a white, bold, sans-serif font.

ENOUGH STATIC NOISE, LETS JUST  
GO WITH THE FLOW...OF  
ELECTRICITY! THIS IS KNOWN AS  
CURRENT!

# CIRCUIT ELEMENTS

## ELECTRICAL CIRCUIT SYMBOLS

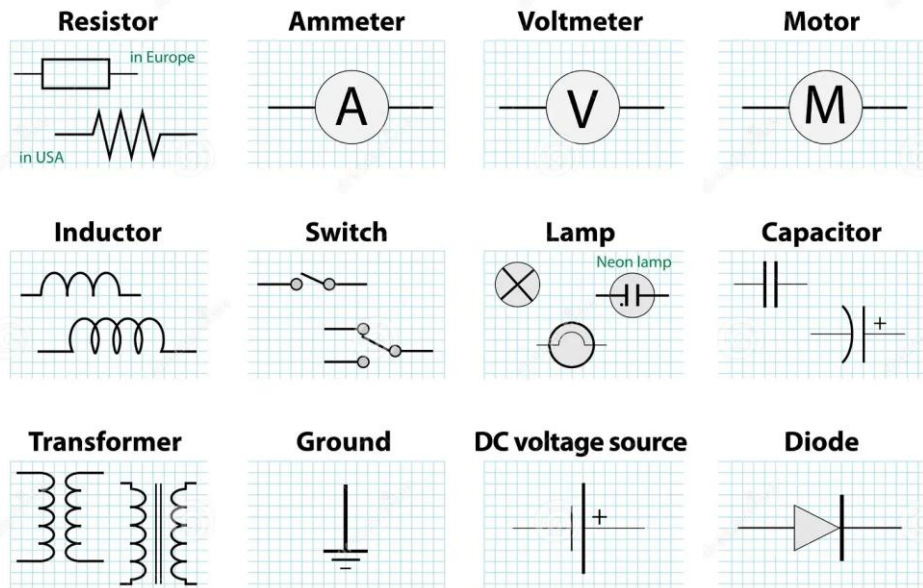

- Batteries have 2 terminals. Electrons in neutral wire are attracted to positive end, leaving wire positive. Electrons from negative end attracted to positives in wire
- Switches are used to close a circuit (turn it on), or open a circuit (turn it off)



## A CIRCUIT IS LIKE A RIVER

- The canoe is an electron
- The canoer is the battery
- The water is charge

# CURRENT

- Speed of charge through a circuit
- Current,  $I$ , is measured in amperes (A), and is the amount of charge,  $Q$ , that passes through a specific point per second, in a circuit.
- An ampere (A) is equal to a coulomb (C, unit of charge) per second
- Ammeter is a device that tells us the current
- Current is in opposite direction as the flow of electrons

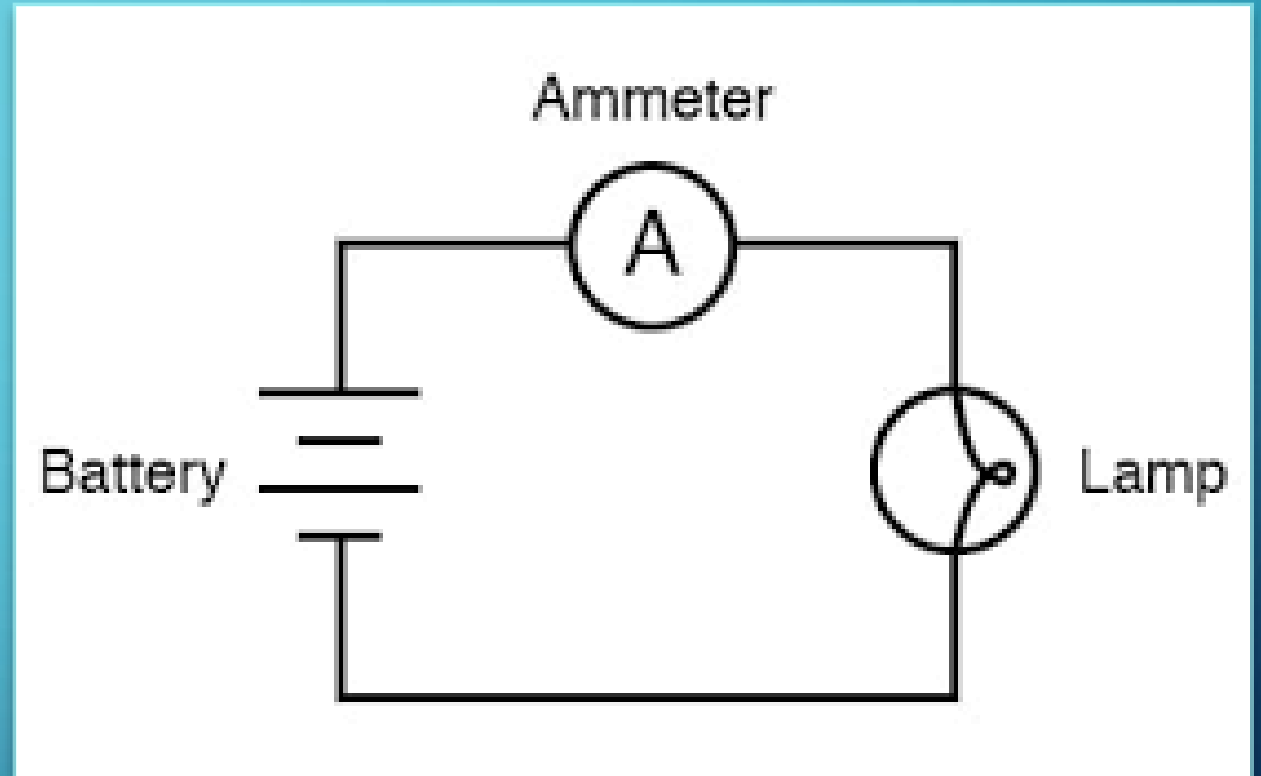

$$I = Q/t$$



## A CIRCUIT IS LIKE A RIVER

- The water is charge
- The speed of the water is the current (current is the speed of the charge)

# POTENTIAL DIFFERENCE (VOLTAGE)

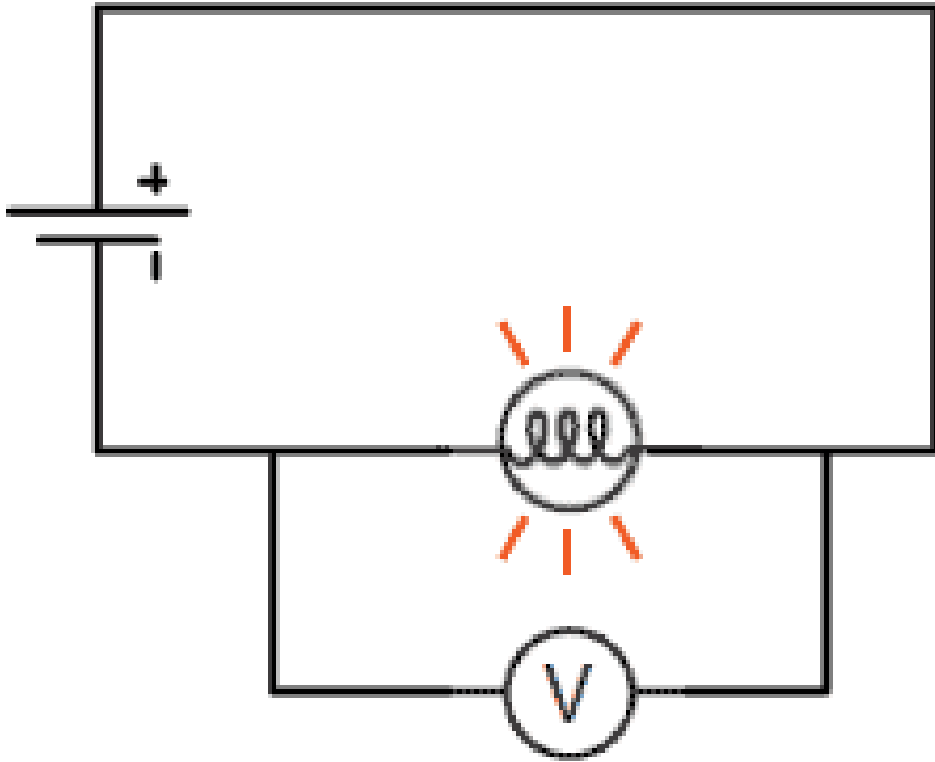

- Total energy stored within a battery is the electrical potential energy,  $E$ , measured in joules (J)
- Potential difference (voltage),  $V$ , is the amount of energy used per coulomb of charge through a section of a circuit.
- It's measured in volts (V), which is equal to a joule per coulomb (J/C)
- Voltmeter is a device that tells us voltage

$$V = E/Q$$



## A CIRCUIT IS LIKE A RIVER

- The water is charge
- The canoer is the battery
- The amount of energy the canoer has is the potential energy
- The amount of energy per row is the voltage/potential difference (energy used per unit of charge)

# RESISTANCE

- Resistors convert electrical energy into a different type of energy (heat, light, etc.)
- They make it harder for electrons to push through the circuit
- This slows down charge (decreasing current)
- So, the higher the resistance, the slower the current

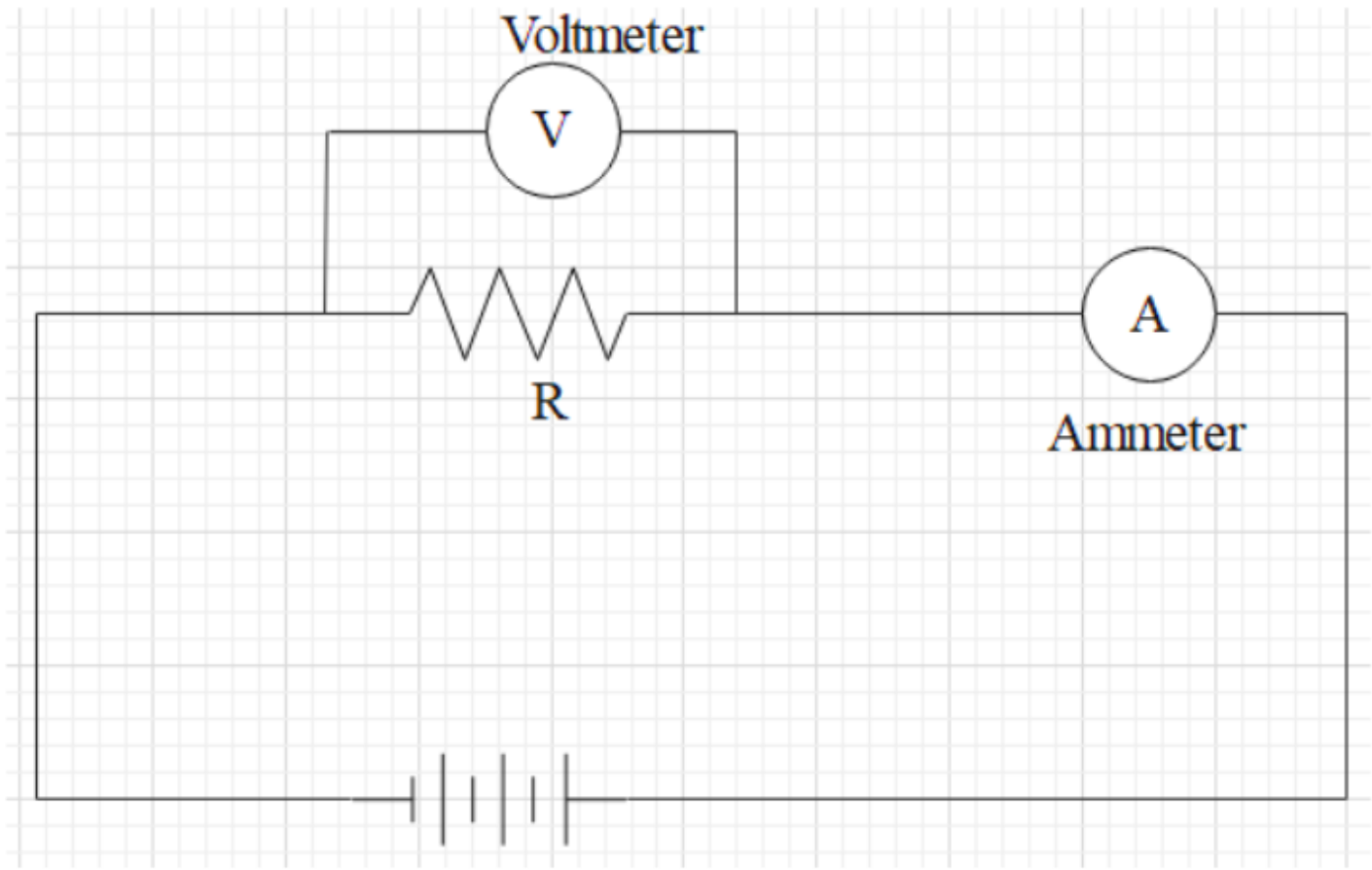

$$R = V / I$$



## A CIRCUIT IS LIKE A RIVER

- The water is charge
- The speed of the water is the current
- The canoe is an electron
- The energy per row is the voltage/potential difference
- The resistance is anything that slows the water & the canoe



NOW YOU GUYS ARE GOING TO  
BECOME A CIRCUIT...



The background is a solid teal color with a gradient. In the corners, there are decorative white line-art patterns resembling circuit board traces and nodes. The text is centered in the upper half of the image.

300C OF CHARGE ARE MOVING THROUGH A  
POINT IN A CIRCUIT EVERY 30 SECONDS, WHAT IS  
THE CURRENT?

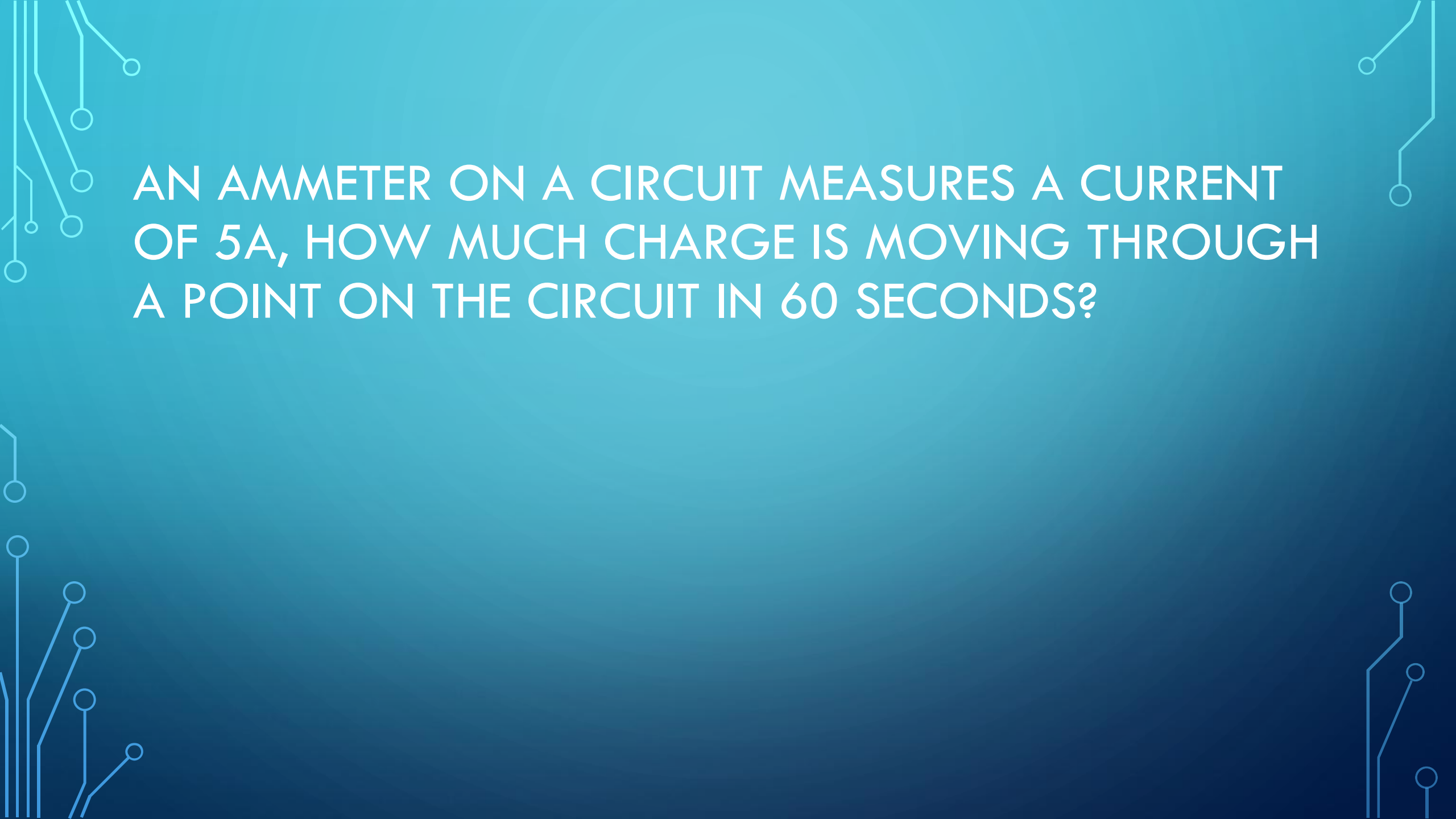
The background is a dark teal gradient. In the corners, there are decorative white line-art patterns resembling circuit board traces and nodes. The text is centered in a white, sans-serif font.

AN AMMETER ON A CIRCUIT MEASURES A CURRENT OF 5A, HOW MUCH CHARGE IS MOVING THROUGH A POINT ON THE CIRCUIT IN 60 SECONDS?

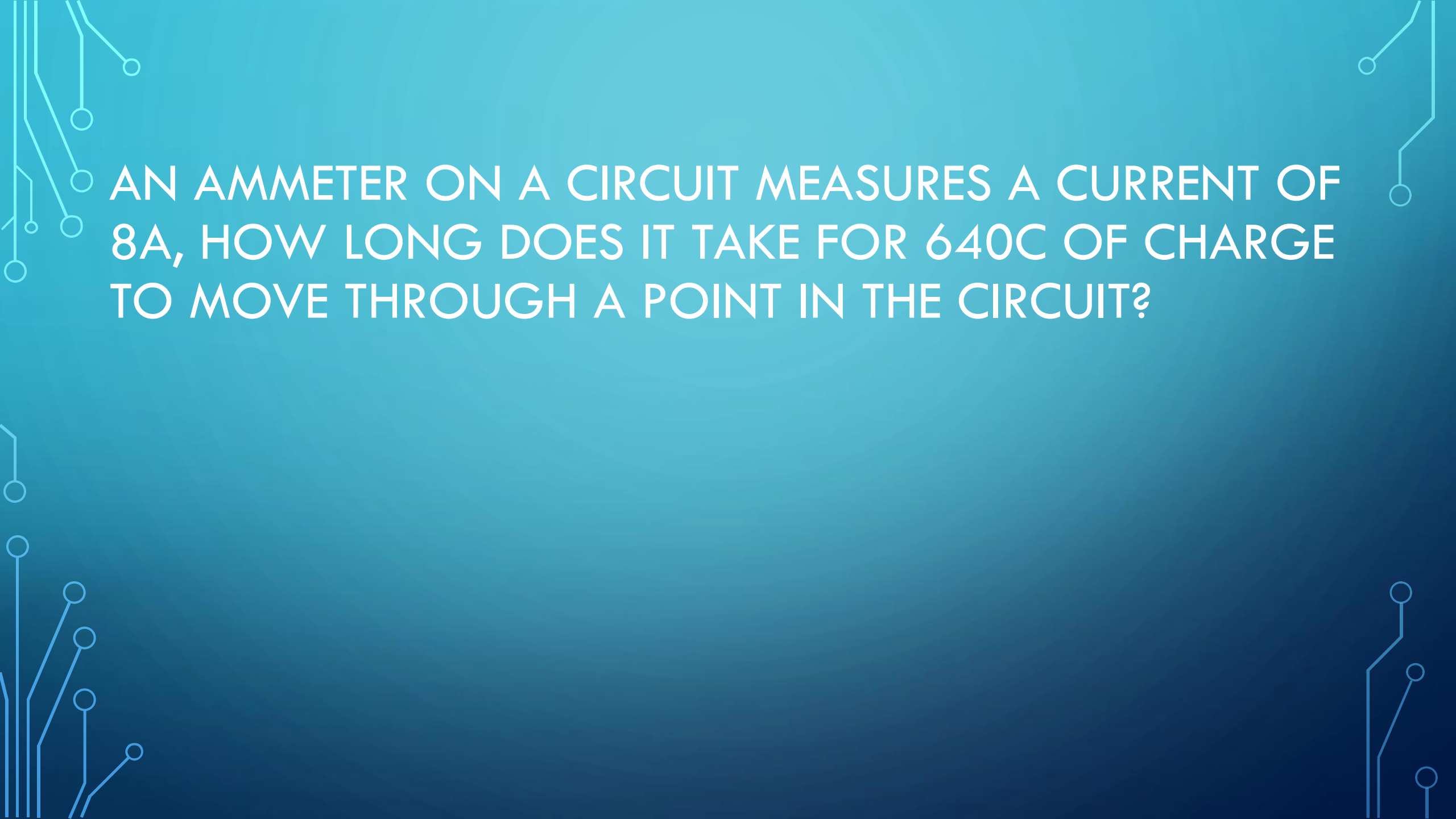

AN AMMETER ON A CIRCUIT MEASURES A CURRENT OF 8A, HOW LONG DOES IT TAKE FOR 640C OF CHARGE TO MOVE THROUGH A POINT IN THE CIRCUIT?

The background is a solid teal color. In the four corners, there are decorative white line-art patterns that resemble circuit board traces and nodes. These patterns are more dense in the bottom-left and top-right corners and more sparse in the top-left and bottom-right corners.

A RESISTOR IN A CIRCUIT USES 5000J (5KJ) OF POTENTIAL ENERGY FOR EVERY 125C OF CHARGE. WHAT IS THE POTENTIAL DIFFERENCE ACROSS THE RESISTOR?

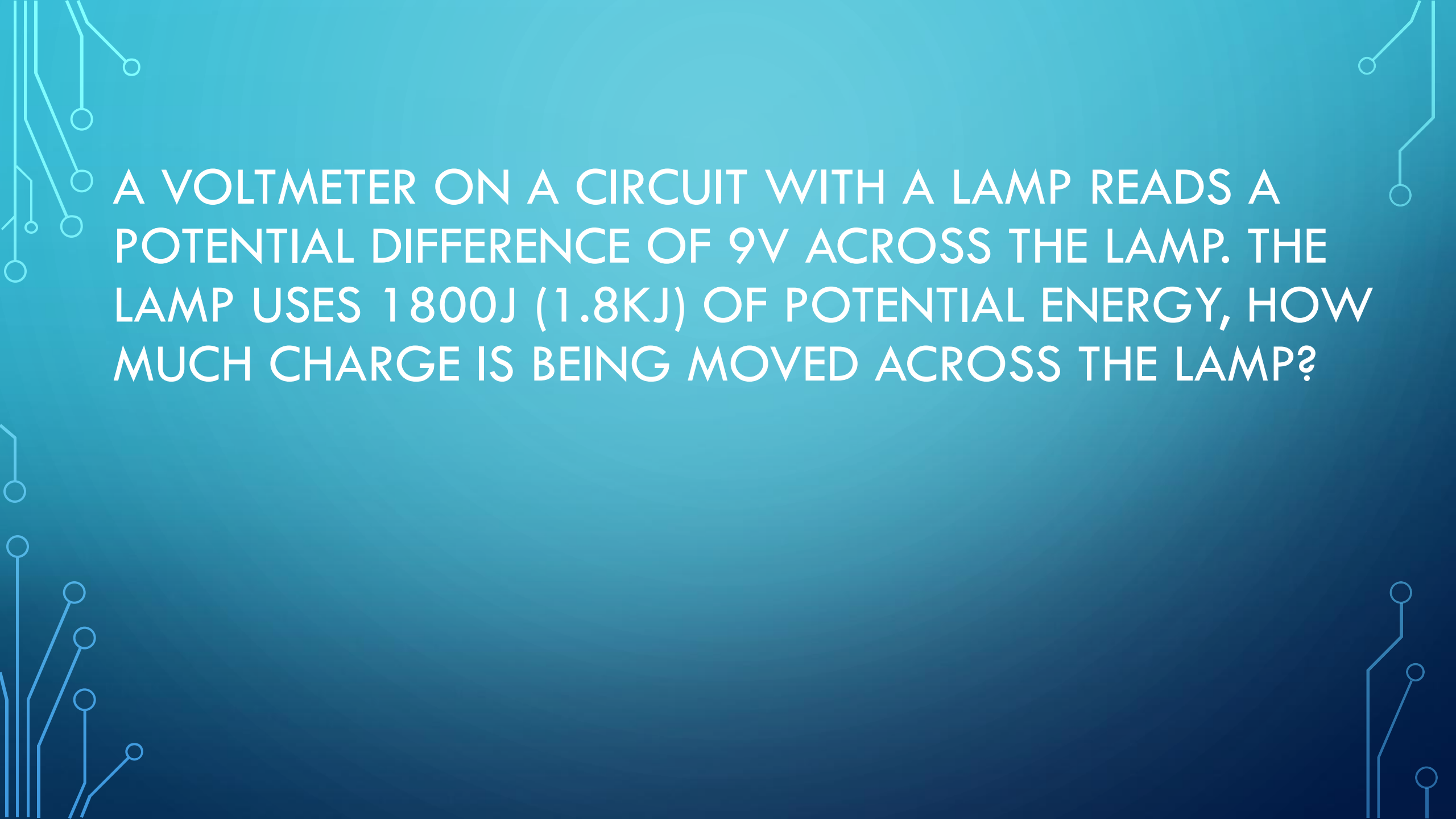
The background is a dark blue gradient. In the corners, there are decorative white line-art patterns resembling circuit board traces and nodes. The text is centered in a white, bold, sans-serif font.

A VOLTMETER ON A CIRCUIT WITH A LAMP READS A POTENTIAL DIFFERENCE OF 9V ACROSS THE LAMP. THE LAMP USES 1800J (1.8KJ) OF POTENTIAL ENERGY, HOW MUCH CHARGE IS BEING MOVED ACROSS THE LAMP?

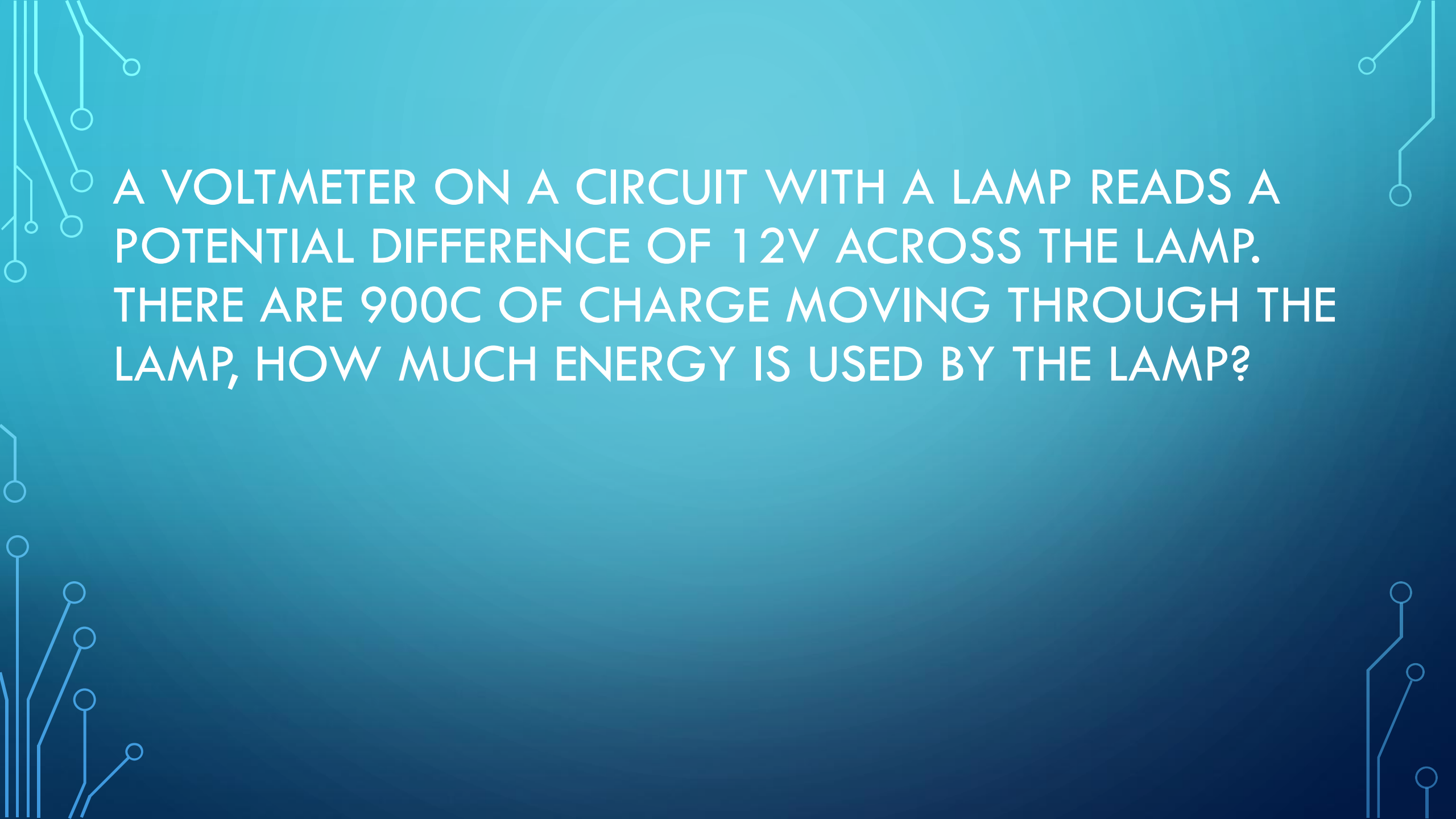
The background is a dark blue gradient. In the corners, there are decorative white line-art patterns resembling circuit board traces and nodes. These patterns are most prominent in the top-left, top-right, and bottom-left corners, with some extending into the bottom-right corner.

A VOLTMETER ON A CIRCUIT WITH A LAMP READS A POTENTIAL DIFFERENCE OF 12V ACROSS THE LAMP. THERE ARE 900C OF CHARGE MOVING THROUGH THE LAMP, HOW MUCH ENERGY IS USED BY THE LAMP?

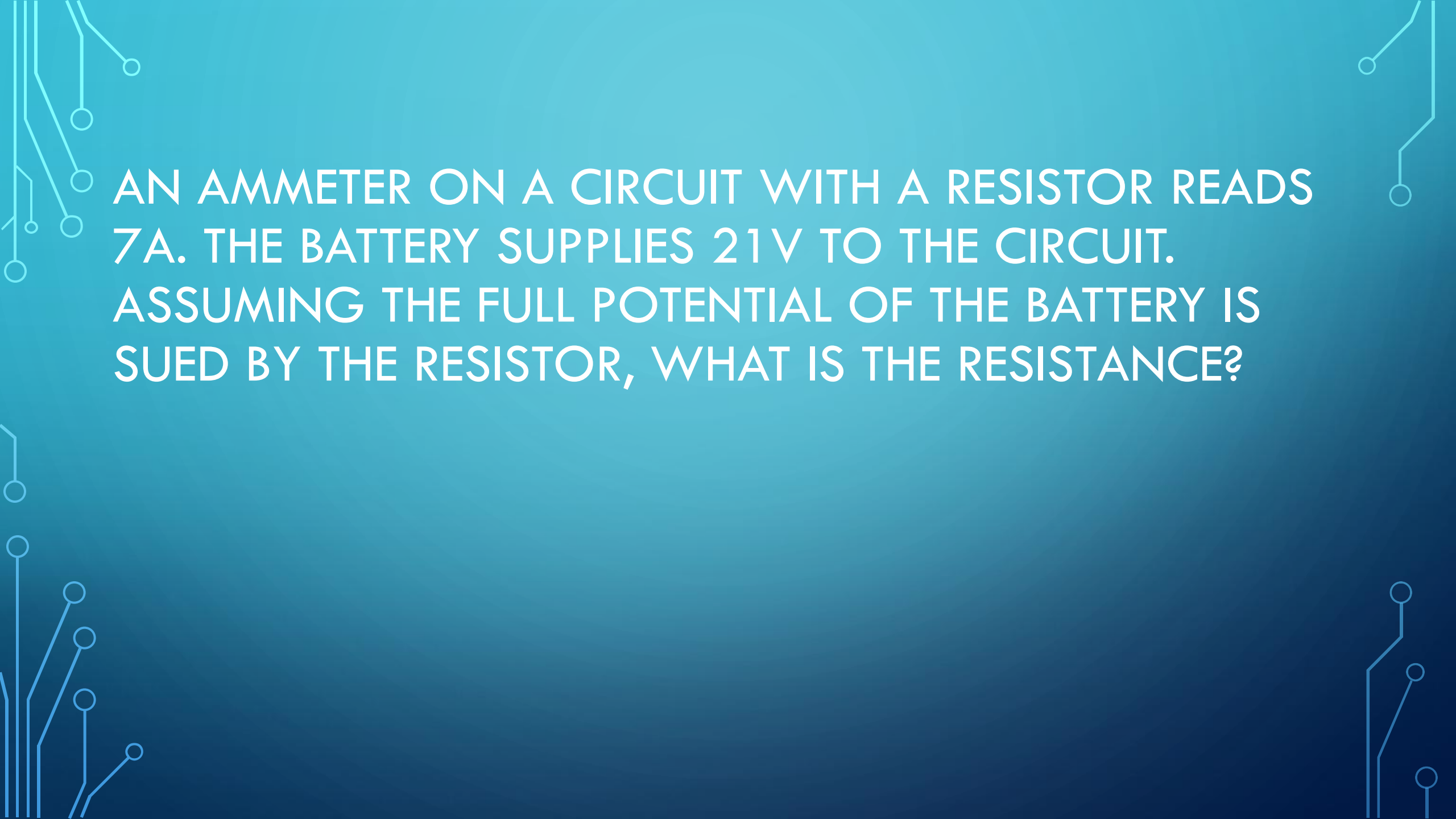
The background is a dark blue gradient. In the corners, there are decorative white line-art patterns resembling circuit board traces and nodes. These patterns are located in the top-left, top-right, bottom-left, and bottom-right corners.

AN AMMETER ON A CIRCUIT WITH A RESISTOR READS 7A. THE BATTERY SUPPLIES 21V TO THE CIRCUIT. ASSUMING THE FULL POTENTIAL OF THE BATTERY IS USED BY THE RESISTOR, WHAT IS THE RESISTANCE?

A  $9\Omega$  RESISTOR IS IN A CIRCUIT WITH AN AMMETER AND A VOLTMETER. THE AMMETER READS 6A. WHAT WOULD THE VOLTMETER READ ACROSS THE RESISTOR?

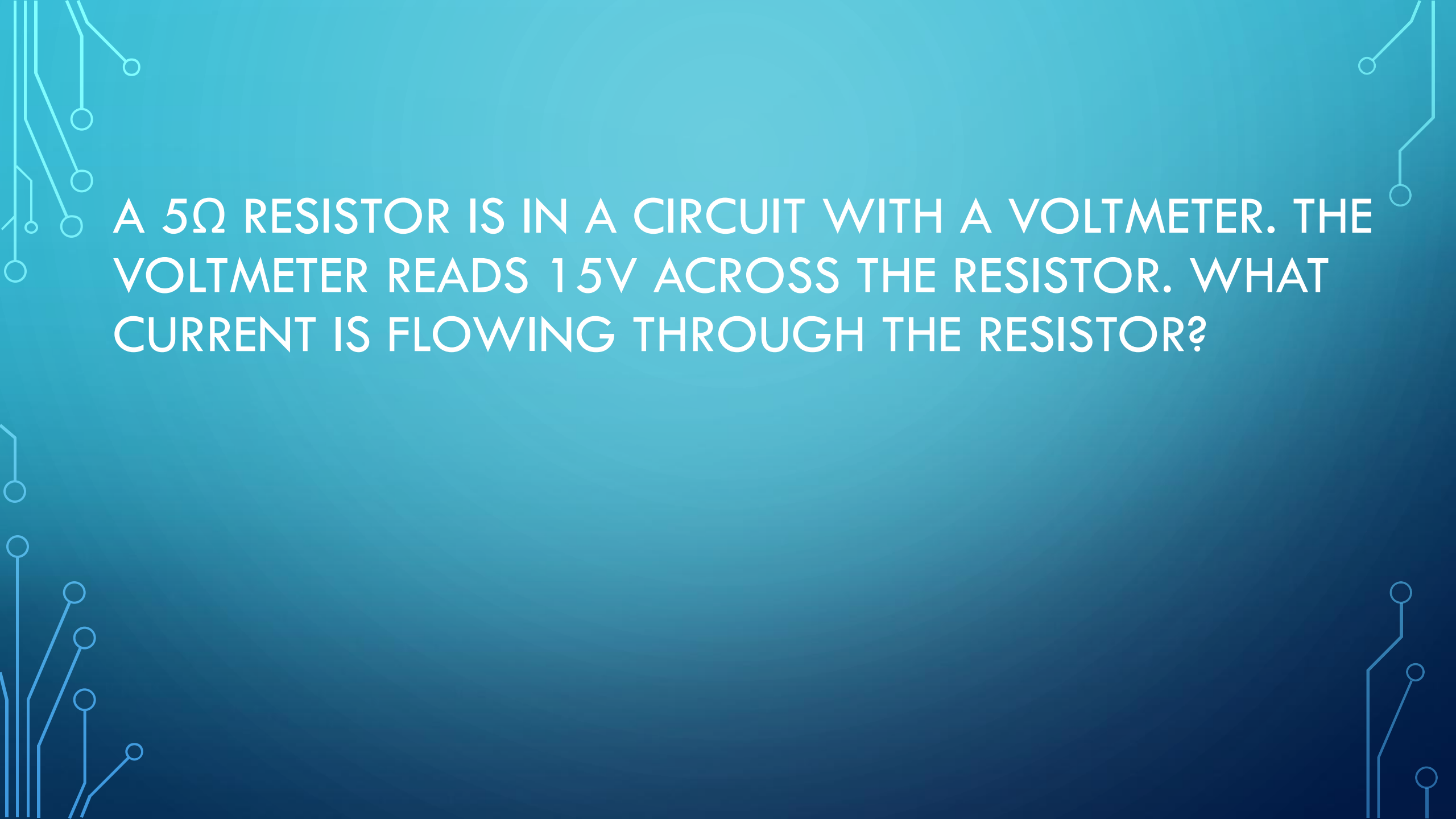
The background is a solid teal color. In the four corners, there are decorative white line-art patterns that resemble circuit board traces and nodes. These patterns are more dense in the top-left and bottom-left corners and more sparse in the top-right and bottom-right corners.

A  $5\Omega$  RESISTOR IS IN A CIRCUIT WITH A VOLTMETER. THE VOLTMETER READS 15V ACROSS THE RESISTOR. WHAT CURRENT IS FLOWING THROUGH THE RESISTOR?



NOW YOU TRY!

